

SWIMMING POOL HEAT PUMP UNIT

Installation & Instruction Manual



CONTENTS

1. Preface

- 1.1 Preface
 - 1.2 Safe precautions
-

2. Specifications

- 2.1 Performance data of swimming pool heat pump unit
 - 2.2 Dimensions for swimming pool heat pump unit
-

3. Installation and Connection

- 3.1 Installation illustration
 - 3.2 Swimming Pool Heat Pumps Location
 - 3.3 How Close To Your Pool?
 - 3.4 Swimming Pool Heat Pumps Plumbing
-

4. Usage and Operation

- 4.1 The functions of the controller
 - 4.2 How to use wire controller
 - 4.3 Operation data setting
-

5. Maintenance and Inspection

- 5.1 Maintenance
 - 5.2 Trouble shooting guide of controller
-

6. Appendix

- 6.1 Connection of PCB illustration
- 6.2 Connections explanation
- 6.3 Connection of protection PCB illustration
- 6.4 Connections explanation

1. PREFACE

1.1 PREFACE

● In order to provide our customers with quality, reliability and versatility, this product has been made to strict production standards. This manual includes all the necessary information about installation, debugging, discharging and maintenance. Please read this manual carefully before you open or maintain the unit. The manufacture of this product will not be held responsible if someone is injured or the unit is damaged, as a result of improper installation, debugging, or unnecessary maintenance. It is vital that the instructions within this manual are adhered to at all times. The unit must be installed by qualified personnel.

- The unit can only be repaired by qualified installer centre personnel or an authorised dealer.
- Maintenance and operation must be carried out according to the recommended time and frequency, as stated in this manual.
- Use genuine standard spare parts only. Failure to comply with these recommendations will invalidate the warranty.
- Swimming Pool Heat Pump Unit heats the swimming pool water and keeps the temperature constant. The indoor unit can be discretely hidden or semi-hidden to suit a luxury house. This type of pump has the following characteristics:

1 Durable

The heat exchanger is made of PVC & titanium tube which can withstand prolonged exposure to corrosives such as chlorine.

2 Installation flexibility

The unit can be installed outdoors or indoors.

3 Quiet operation

The unit comprises an efficient rotary/ scroll compressor and a low-noise fan motor, which guarantees its quiet operation.

4 Advanced controlling

The unit includes micro-computer controlling, allowing all operation parameters to be set. Operation status can be displayed on the wire controller. You can also choose remote controlling.

6. APPENDIX

6.3 Connection of protection PCB illustration

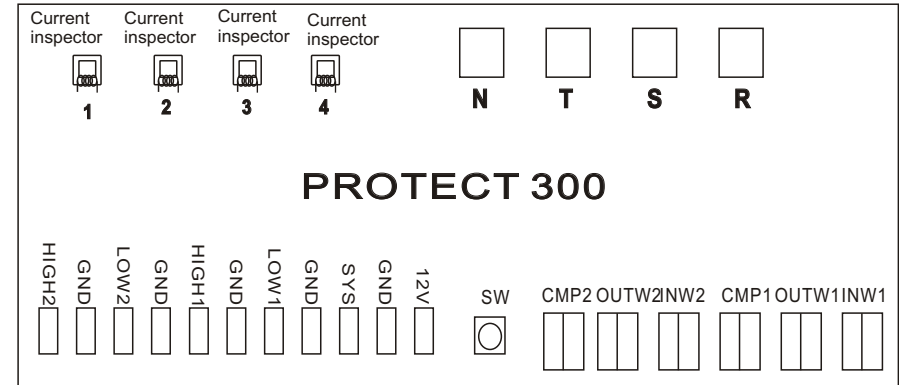

6.4 You can judge and remove the malfunctions according to the malfunction code display on the PROTECT 300

Display	Name	reason	Action	Recover (yes or no)	revolution
1	Refrigerant freezing	Refrigerant temp. too low from tube outlet	Unit stops and alarm	Yes	Reduce refrigerant
2	Refrigerant leakage	Refrigerant temp. before tube inlet too low	Unit stops and alarm	Yes	Increase refrigerant
3	Low pressure	Low pressure switch action	Unit stops and alarm	Yes	Check through the pressure switch and return system
4	Compressor exhaust temp. too high	Compressor exhaust temp. too high	Unit stops and alarm	Yes	Check through the refrigerant system
5	Over-current on compressor	Current through compressor too heavy	Unit stops and alarm	Yes	Check through the power supply for compressor or short circuit
6	High pressure	High pressure switch action	Unit stops and alarm	Yes	Check through the pressure switch and return system
7	Temp. sensor before tube failure	Temp. Sensor open or short circuit	Unit stops and alarm	Yes	Check and renew the sensor
8	Tube outlet temp. sensor failure	Temp. Sensor open or short circuit	Unit stops and alarm	Yes	Check and renew the sensor
9	Exhaust temp. sensor failure	Temp. Sensor open or short circuit	Unit stops and alarm	Yes	Check and renew the sensor
E	Power supply wrong connection	Wrong connection or lack of connection	Unit stops and alarm	Yes	Check the connections

6. APPENDIX

6.1 Connection of PCB illustration

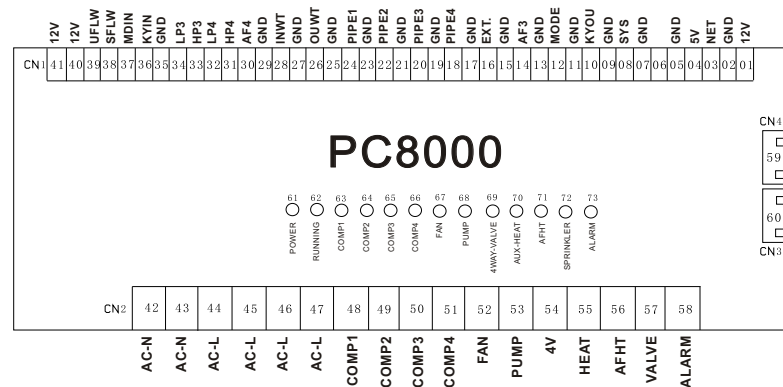

6.2 Connections explanation:

Number	Meaning	Number	Meaning
01	+12VDC for wire controller	35	GND for PCB
02	GND for wire controller	36	On/Off switch(input)
03	Signal for wire controller	37	Mode input
04	+5VDC	38	Ground source flow switch
05	GND for PCB	39	Using side flow switch
07	GND for PCB	40	+12VAC input(tansformer)
08	System protect	41	- 12VAC input(tansformer)
10	On/Off switch(output)	42	Neutral wire
11	GND for PCB	43	Neutral wire
12	Mode input	44	Live wire
13	GND for PCB	45	Live wire
15	GND for PCB	46	Live wire
16	External temperature	47	Live wire
17	GND for PCB	48	Compressor of system1
18	System4 pipe4 temperature	49	Compressor of system2
19	GND for PCB	50	Compressor of system3
20	System3 pipe4 temperature	51	Compressor of system4
21	GND for PCB	52	Fan motor
22	System2 pipe4 temperature	53	Water pump
23	GND for PCB	54	4Way valve
24	System1 pipe4 temperature	55	Auxiliary heating
25	GND for PCB	56	Antifreeze heater
26	Outlet water temperature	57	Sprinkler
27	GND for PCB	58	Alarm output
28	Inlet water temperature		
29	GND for PCB		

1.PREFACE

1.2 Safety precautions



ELECTRICAL POWER MUST BE SWITCHED OFF BEFORE STARTING ANY WORK ON JUNCTION BOXES

The aim of this manual is to provide instructions for installation, commissioning, operation.

WARNING !

The installation, commissioning and maintenance of these machines should be performed by qualified personnel having a good knowledge of standards and local regulations, as well as experience of this type of equipment.

WARNING !

Any wiring produced on site must comply with local electrical regulations.

WARNING !

Ensure that the electrical supply corresponds to the specification indicated on the unit's maker's plate before proceeding with the connection in accordance with the wiring diagram supplied.

WARNING !

The unit must be EARTHED to avoid any risks caused by insulation defects.

WARNING !

No wiring must come in contact with the heat source or the fan rotating parts.

WARNING !

Preparation for shutting down the unit for a prolonged period if the installation does not contain glycol, the evaporator and the chilled water pipes need to be carefully and completely drained of water.

WARNING!

In preparation for shutting down the unit for a prolonged period the condenser and the chilled water pipes on the reversible unit need to be carefully flushed with fresh water(during 15 minutes by the outlet) and then completely drained of water.

The Manufacturers warranty will not apply if the installation recommendations listed in this manual are not followed.

Take care !

The unit should be handled using lifting and handling equipment appropriate to the unit's size and weight.

Take care !

It is forbidden to start any work on the electrical components without switching off the electrical supply to the unit.

Take care !

It is forbidden to start any work on the electrical components if water or high humidity is present on the installation site.

Take care !

When the unit is being connected, ensure that no impurities are introduced into the pipe work and the water circuits.

Take care!

The setting water temperature can not over 40 °C , (105°F) to assure the unit running safety.

Take care!

An insulated pipe for protection must be used for the 3-core signal wire at the wire outlet for outdoor installation.

Take care!

Use copper supply wires.

2.SPECIFICATION

2.1 Performance data of Swimming Pool Heat Pump Unit

Unit	Model	03310160
Heating Capacity	kW	210
	BTU/h	714000
Heating Power Input	kW	46.3
Heating Running Current	A	81.8
Cooling Capacity	kW	150
	BTU/h	510000
Cooling Power Input	kW	56.2
Cooling Running Current	A	99.1
Power Supply	V/PH/Hz	380/3/50
Compressor Quantity		4
Compressor		scroll
Fan Quantity		4
Fan Power Input	W	550×4
Fan Rotate Speed	RPM	870
Fan Direction		vertical
Noise	dB(A)	65
Water Connection	mm	110
Water Flow Volume	m ³ /h	60
Water Pressure Drop(MAX)	kPa	21
Unit Net Dimensions(L/W/H)	mm	see the drawing of the units
Unit Shipping Dimensions(L/W/H)	mm	see package label
Net Weight	kg	see nameplate
Shipping Weight	kg	see package label

5. MAINTENANCE AND INSPECTION

5.2 Trouble Shooting Guide

Malfunction	Error code	Reason	Resolution
Watertemp.difference between inlet and outlet over much	E03	Water flow rate not enough	Check the water flow rate, or water system is jammed or not
Too cool protection	E05	Water flow rate not enough	Check the water flow rate, or water system is jammed or not
Power phase failure	E09	Wrong connections or lack of connection	Check connections of power cable
System 1 high pressure switch off	E12	Gas charge too high . Possible system blockage	Check through each pressure switch and return circuit
System 2 high pressure switch off	E22	Gas charge too high . Possible system blockage	Check through each pressure switch and return circuit
System 3 high pressure switch off	E32	Gas charge too high . Possible system blockage	Check through each pressure switch and return circuit
System 4 high pressure switch off	E42	Gas charge too high . Possible system blockage	Check through each pressure switch and return circuit
System 1 low pressure switch off	E11	Gas charge too low . Possible system Leakage	Check through each pressure switch and return circuit
System 2 low pressure switch off	E21	Gas charge too low . Possible system Leakage	Check through each pressure switch and return circuit
System 3 low pressure switch off	E31	Gas charge too low . Possible system Leakage	Check through each pressure switch and return circuit
System 4 low pressure switch off	E41	Current through compressor too heavy	Check through the power supply for compressor or short circuit
Overload protection for system 1	E13	Current through compressor too heavy	Check through the power supply for compressor or short circuit
Overload protection for system 2	E23	Current through compressor too heavy	Check through the power supply for compressor or short circuit
Overload protection for system 3	E33	Current through compressor too heavy	Check through the power supply for compressor or short circuit
Overload protection for system 4	E43	Current through compressor too heavy	Check through the power supply for compressor or short circuit

5. MAINTENANCE AND INSPECTION

5.1 Maintenance

- Check the water supply device and the release often. You should avoid the condition of no water or air entering into system, as this will influence unit's performance and reliability. You should clear the pool/spa filter regularly to avoid damage to the unit as a result of the dirty or clogged filter.
- The area around the unit should be dry, clean and well ventilated. Clean the side heating exchanger regularly to maintain good heat exchange and conserve energy.
- The operation pressure of the refrigerant system should only be serviced by a certified technician.
- Check the power supply and cable connection often, should the unit begin to operate abnormally, switch it off and contact your certified Poolrite technician.
- Discharge all water in the water pump and water system, so that freezing of the water in the pump or water system does not occur. You should discharge the water at the bottom of water pump if the unit will not be used for an extended period of time. You should check the unit thoroughly and fill the system with water fully before using it for the first time after a prolonged period of no usage.

5.2 Trouble Shooting Guide

Malfunction	Error code	Reason	Resolution
Inlet water temp. failure	P01	The sensor is open or short circuit	Check or change the sensor
Outlet water temp. failure	P02	The sensor is open or short circuit	Check or change the sensor
Ambient temp. failure	P03	The sensor is open or short circuit	Check or change the sensor
Water flow protection	P08	No water/little water in water system.	Check the water flow volume, water pump is failure or not
Brine Water flow protection	P09	No water/little water in ground source water system.	Check the water flow volume, water pump is failure or not
System 1 pipe temp. failure	P13	The sensor is open or short circuit	Check or change the sensor
System 2 pipe temp. failure	P23	The sensor is open or short circuit	Check or change the sensor
System 3 pipe temp. failure	P33	The sensor is open or short circuit	Check or change the sensor
System 4 pipe temp. failure	P43	The sensor is open or short circuit	Check or change the sensor
System 1 tube1 outlet temp.	P15	The sensor is open or short circuit	Check or change the sensor
System 1 tube2 outlet temp.	P16	The sensor is open or short circuit	Check or change the sensor
System 2 tube1 outlet temp.	P25	The sensor is open or short circuit	Check or change the sensor
System 2 tube2 outlet temp.	P26	The sensor is open or short circuit	Check or change the sensor
System 3 tube1 outlet temp.	P35	The sensor is open or short circuit	Check or change the sensor
System 3 tube2 outlet temp.	P36	The sensor is open or short circuit	Check or change the sensor
System 4 tube1 outlet temp.	P45	The sensor is open or short circuit	Check or change the sensor
System 4 tube2 outlet temp.	P46	The sensor is open or short circuit	Check or change the sensor

2. SPECIFICATION

2.2 The dimensions for Swimming Pool Heat Pump Unit

Model : 03310160

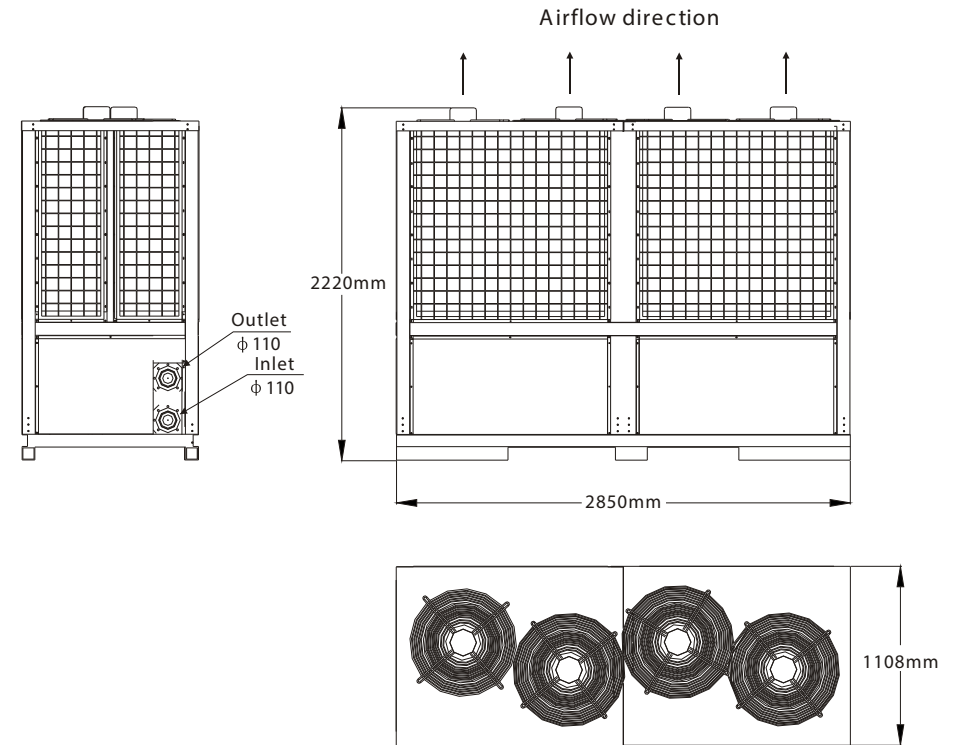

3.INSTALLATION AND CONNECTION

3.1 Installation illustration

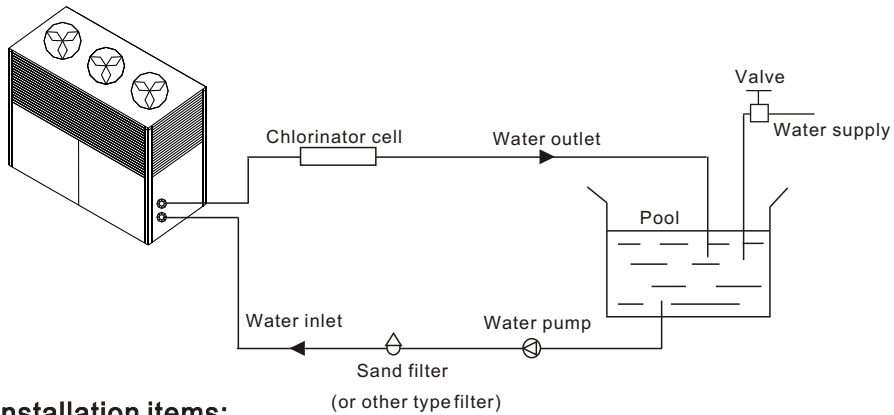

Installation items:

The factory only provides the main unit and the water unit; the other items in the illustration are necessary spare parts for the water system, that provided by users or the installer.

Attention:

Please follow these steps when using for the first time

1. Open valve and charge water.
2. Make sure that the pump and the water-in pipe have been filled with water.
3. Close the valve and start the unit.
4. single wall heat exchanger, not suitable for potable water connection.
5. We don't provide the field wiring connection, please choose the wiring allow the Minimum Circuit Ampacity.

4. USAGE AND OPERATION

4.3 Operation Data Setting

The unit's operation data can be set on the wire controller. Please set according the below table:

Parameter	Description	Range	Default
Cool temp.	Cooling set point	8-28℃	27℃
Heat temp.	Heating set point	15-40℃	27℃
Def. cyc	Delay between 2 defrosting cycle requests within the same circuit	30-90min	40min
Def. in temp	Start defrosting temperature	0-30℃	-7℃
Def. out temp.	End defrosting temperature	2-30min	13℃
Def. time	Max.duration of a defrosting cycle	1-12min	8min
System number	Number of compressors	3-4	4
Power save	Power-down memory	Yes/No	Yes
Mode type	Unit model:C(chiller);H(heat pump);A(Auto)	C-C+H-A+C+H-H	C/H
Pump mode	Normal:always ON(alarm is managed) Special:ON when called by compressor (the alarm is managed)	Normal/Special	Normal
Unit type	Unit model 0(Air-water);1(water-water)	0-1	0
Pump ahead	Flow switch alarm delay when starting the pump	1-10min	1min

4. USAGE AND OPERATION

f) Curve

When standby, press “ **Prg** ” to enter into menu surface.

Then, press “ **▲▼** ” to choose temperature curve option and use the key “ **←** ” to check it.

Using “ **▲▼** ” again to select temperature sensor curve and press “ **←** ” to check it.

And this key “ **Esc** ” can back to front page.

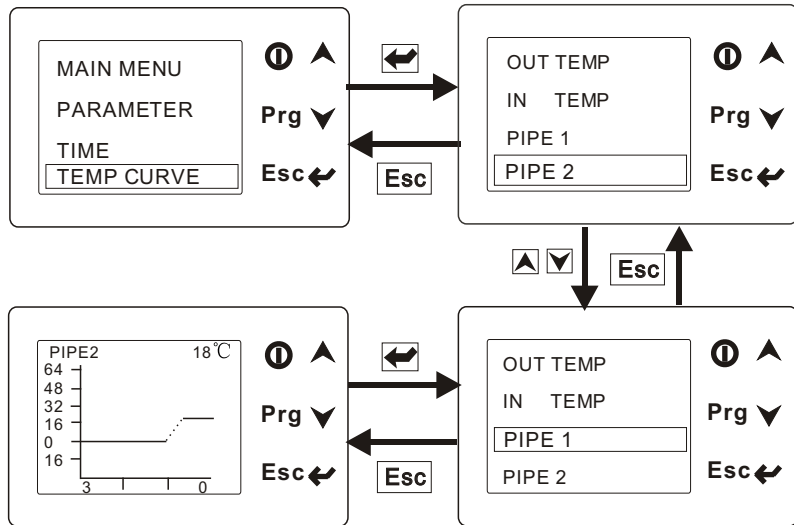

3.INSTALLATION AND CONNECTION

3.2 Swimming Pool Heat Pumps Location

The unit will perform well in any outdoor location provided that the following three factors are present .

1. Fresh Air - 2. Electricity - 3. Pool filter piping

The unit may be installed virtually anywhere outdoors. For indoor pools consult the supplier. Unlike a gas heater, it has no draft or pilot light problem in a windy area.

DO NOT place the unit in an enclosed area with a limited air volume, where the units

discharge air will be re-circulated. DO NOT place the unit to shrubs which can block air inlet. These locations deny the unit of a continuous source of fresh air which reduces it efficiency and may prevent adequate heat delivery.

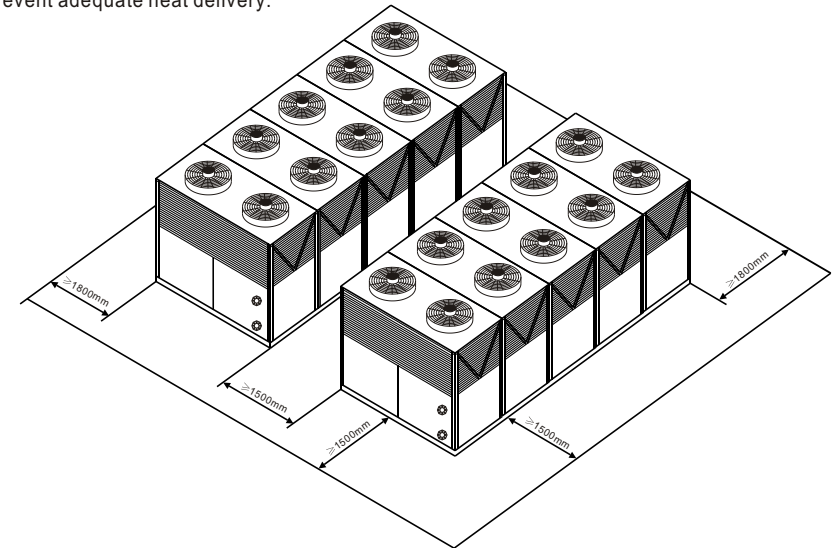

3.3 How Close To Your Pool?

Normally, the pool heat pump is installed within 7.5 metres of the pool. The longer the distance from the pool, the greater the heat loss from the piping. For the most part ,the piping is buried. Therefore,the heat loss is minimal for runs of up to15 metres (15 metres to and from the pump = 30 metres total), unless the ground is wet or the water table is high. A very rough estimate of heat loss per 30 metres is 0.6 Kw-hour,(2000BTU) for every 5 difference in temperature between the pool water and the ground surrounding the pipe, which translates to about 3% to 5% increase in run time.

3. INSTALLATION AND CONNECTION

3.4 Swimming Pool Heat Pumps Plumbing

The Swimming Pool Heat Pumps exclusive rated flow titanium heat exchanger requires no special plumbing arrangements except bypass (please set the flow rate according to the nameplate). The water pressure drop is less than 10kPa at max. Flow rate. Since there is no residual heater flame temperatures, The unit does not need copper heatsink piping. PVC pipe can be run straight into the unit.

Location: Connect the unit in the pool pump discharge (return) line downstream of all filter and pool pumps, and upstream of any chlorinators, ozonators or chemical pumps.

Standard model have slip glue fittings which accept 40mm NB PVC pipe for connection to the pool or spa filtration piping. By using a 50 NB to 40NB you can plumb 50NB PVC piping straight into the unit.

Give serious consideration to adding a quick coupler fitting at the unit inlet and outlet to allow easy draining of unit for winterizing and to provide easier access should servicing be required.

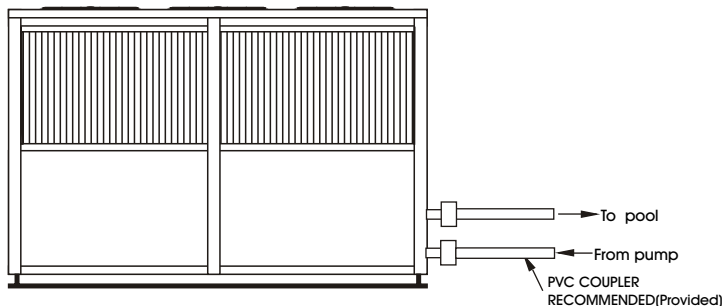

Condensation: Since the Heat pump cools down the air about 4 -5°C, water may condense on the fins of the horseshoe shaped evaporator. If the relative humidity is very high, this could be as much as several litres an hour. The water will run down the fins into the basepan and drain out through the barbed plastic condensation drain fitting on the side of the basepan. This fitting is designed to accept 3/4" clear vinyl tubing which can be pushed on by hand and run to a suitable drain. It is easy to mistake the condensation for a water leak inside the unit.

NB: A quick way to verify that the water is condensation is to shut off the unit and keep the pool pump running. If the water stops running out of the basepan, it is condensation. AN EVEN QUICKER WAY IS to TEST THE DRAIN WATER FOR CHLORINE - if there is no chlorine present, then it's condensation.

4. USAGE AND OPERATION

e) Time setting

When standby, press “ Prg ” key to enter into menu surface. Then, press “ ▲ ▼ ” to select time setting mode and the “ ← → ” key to begin time setting. You can use this key “ ▲ ▼ ” to change parameter. The same way for modify time parameter. Press this “ ← → ” again to confirm it and use “ Esc ” to back to submenu.

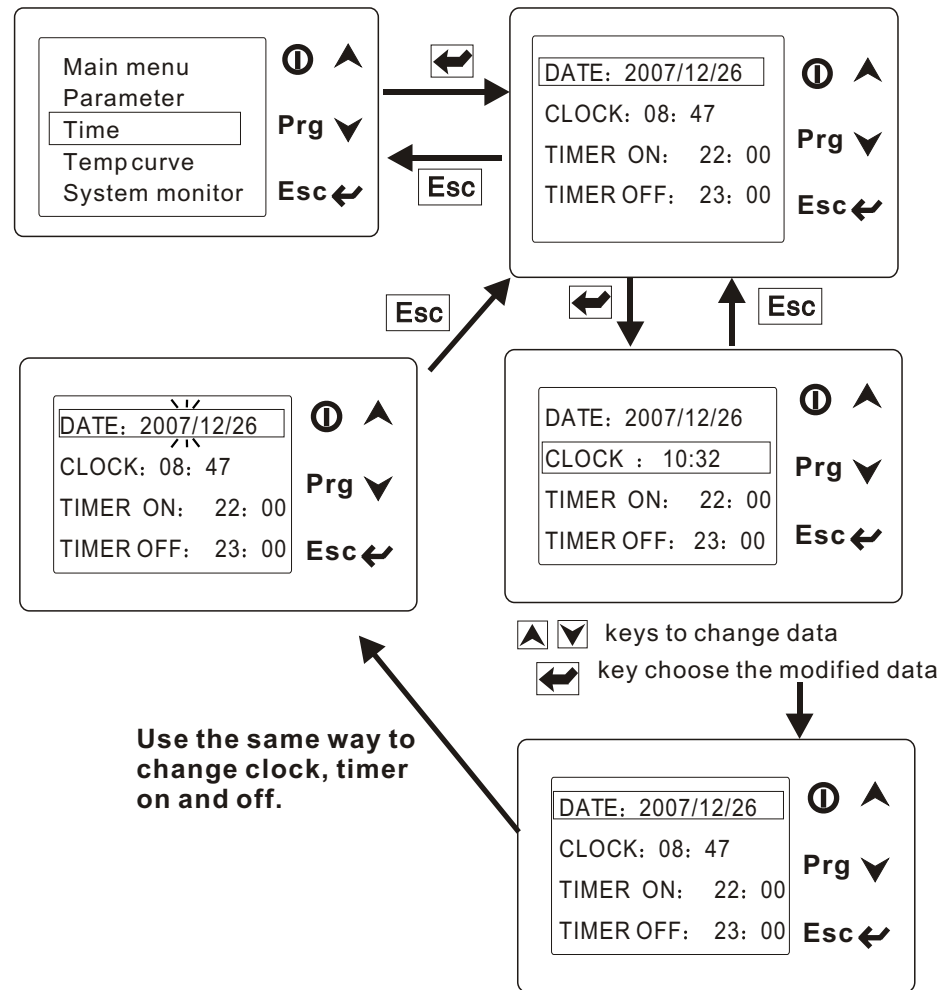

4. USAGE AND OPERATION

d) Parameter

When standby, press “ **Prg** ” key to enter into menu surface. Then, press the “ **▲▼** ” key to select parameter setting and the “ **↵** ” key to begin setting. You can use this key “ **▲▼** ” to change parameter. And the same way for modify time parameter. Press this “ **Esc** ” again to confirm it and use the “ **↵** ” key to back to submenu.

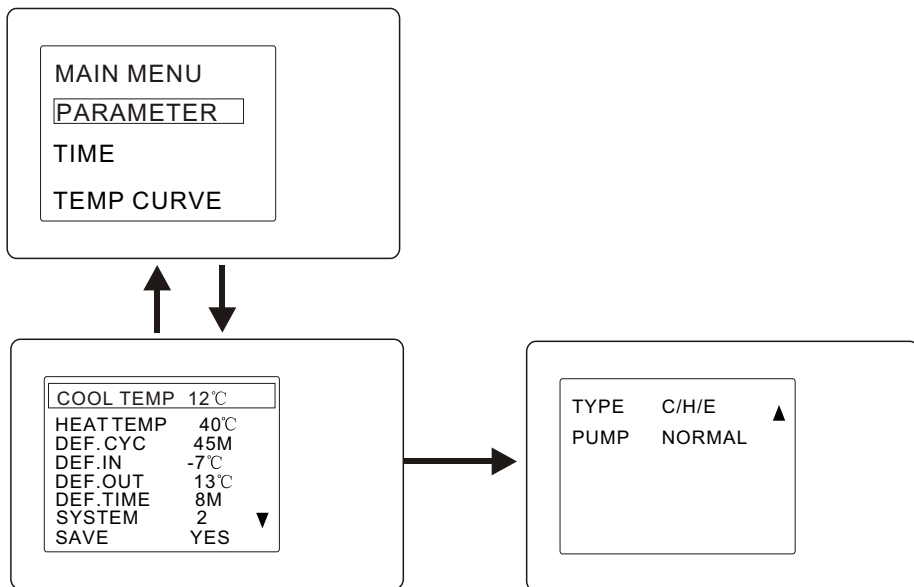

4. USAGE AND OPERATION

4.1 The Functions of the Controller

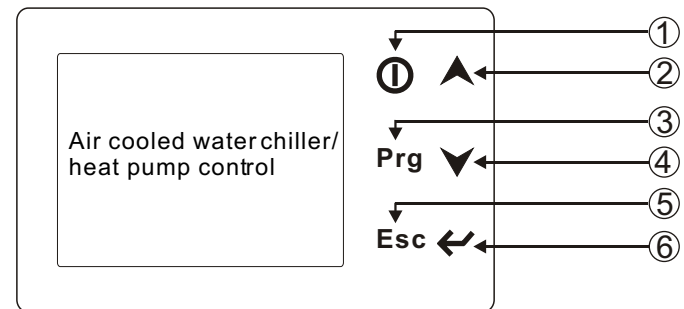

① Switch Key

Press this key to switch on/off;

②④ Up/down Key

Press this key to read parameters in any state in standby or power off.

Press this key to change the parameter in setting state.

③ Menu Key

You can press this key to enter into menu surface when power on or in standby.

⑤ Exit

Press this key to confirm the parameter in setting state.

When in other states, you can press this key to return to the former surface.

⑥ Enter Key

Press up/down key to enter into parameter roll, then press enter key to go into parameter list and change the data.

4. USAGE AND OPERATION

4.2 How to use the remote controller:

a) when power on, it shows:

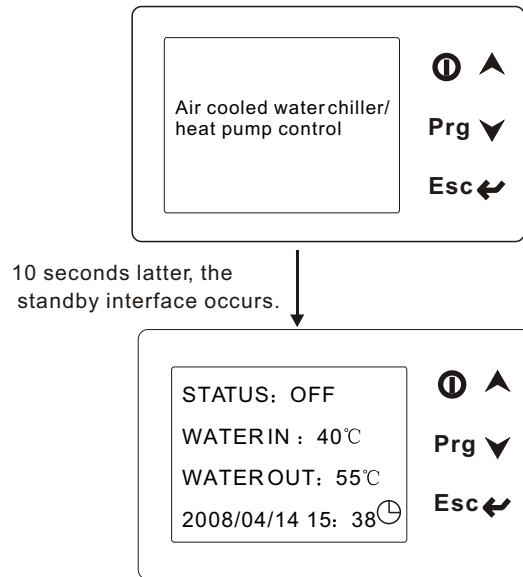

b) After press " ⓘ ", the unit will run.
The display is as follows:

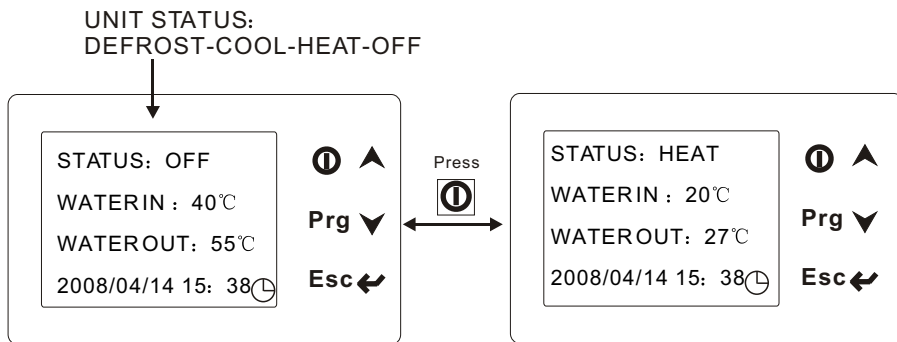

4. USAGE AND OPERATION

c) Main menu

When it is running, press the " Prg " key to enter into menu surface,
Then press the " ▲ ▼ " key to enter into main menu
And press the " ← " key to enter the next menu.
At last, pressing the " Esc " key can come back to the front page.

